

STIHL

STIHL FS-KM

Instruction Manual



Contents

KombiSystem	2
Guide to Using this Manual	2
Safety Precautions and Working Techniques	2
Approved KombiEngines	10
Approved Combinations of Cutting Attachment, Deflector, Handle and Harness	11
Mounting the KombiTool	13
Mounting the Deflector	13
Mounting the Cutting Attachment	14
Fitting the Harness	17
Balancing the Machine	18
Starting / Stopping the Engine	19
Transporting the Unit	19
Lubricating the Gearbox	22
Storing the Machine	22
Sharpening Metal Cutting Blades	23
Maintaining the Mowing Head	23
Maintenance and Care	25
Minimize Wear and Avoid Damage	25
Main Parts	26
Specifications	27
Maintenance and Repairs	29
Disposal	29
EC Declaration of Conformity	29
UKCA Declaration of Conformity	30

Dear Customer,

Thank you for choosing a quality engineered STIHL product.

It has been built using modern production techniques and comprehensive quality assurance. Every effort has been made to ensure your satisfaction and trouble-free use of the product.

Please contact your dealer or our sales company if you have any queries concerning this product.

Your



Dr. Nikolas Stihl

STIHL

FS-KM

This instruction manual is protected by copyright. All rights reserved, especially the rights to reproduce, translate and process with electronic systems.

KombiSystem

In the STIHL KombiSystem a number of different KombiEngines and KombiTools can be combined to produce a power tool. In this instruction manual the functional unit formed by the KombiEngine **and** KombiTool is referred to as the power tool.

Therefore, the separate instruction manuals for the KombiEngine and KombiTool should be used together for the power tool.

Always read and and make sure you understand **both** instruction manuals before using your power tool for the first time and keep them in a safe place for future reference.

Guide to Using this Manual

Pictograms

All the pictograms attached to the machine are shown and explained in this manual.

Symbols in text



Warning where there is a risk of an accident or personal injury or serious damage to property.



Caution where there is a risk of damaging the machine or its individual components.

Engineering improvements

STIHL's philosophy is to continually improve all of its products. For this reason we may modify the design, engineering and appearance of our products periodically.

Therefore, some changes, modifications and improvements may not be covered in this manual.

Safety Precautions and Working Techniques



Some special safety precautions must be observed to reduce the risk of personal injury when operating this power tool because of the very high speed and sharpness of its cutting attachment.



Always read and and make sure you understand both user manuals (KombiEngine and KombiTool) before using your power tool for the first time and keep them in a safe place for future reference. Non-compliance with the user manuals may cause serious or even fatal injury.

Lend or rent your machine only to persons who are familiar with this model and its operation – do not lend or rent your machine without the KombiEngine and KombiTool user manuals.

Depending on the cutting attachment fitted, use your power tool only for cutting grass, wild growth, shrubs, scrub, bushes, small diameter trees and similar materials.

The machine must not be used for any other purposes – **risk of accidents!**

Only use cutting attachments and accessories that are explicitly approved for this power tool model by STIHL or

are technically identical. If you have any questions in this respect, consult your dealer.

Use only high-quality parts and accessories. In order to avoid the risk of accidents and damage to the machine.

STIHL recommends the use of original STIHL tools, cutting attachments and accessories. They are specifically designed to match the product and meet your performance requirements.

The guard provided with your machine may not protect the operator from all foreign objects (gravel, glass, wire etc.) ejected by the revolving cutting attachment. Ejected objects may also ricochet and strike the operator.

Never attempt to modify your power tool in any way since this may increase the risk of personal injury. STIHL excludes all liability for personal injury and damage to property caused while using unauthorized attachments.

Do not use a high-pressure washer to clean the power tool. The solid jet of water may damage parts of the unit.

Clothing and equipment

Wear proper protective clothing and equipment.



Clothing must be robust but allow complete freedom of movement. Wear close-fitting clothes such as a boiler suit, not a loose jacket.

Do not wear clothing which could become trapped in wood, brush or moving parts of the machine. Do not

wear a scarf, necktie or jewelry. Tie up and confine long hair above your shoulders.



Wear safety boots with steel toe caps and non-slip soles.

Sturdy shoes with non-slip soles are permissible only when using mowing heads.



WARNING



To reduce the risk of eye injuries, wear close-fitting safety glasses in accordance with European Standard EN 166. Make sure the safety glasses are a snug fit.

Wear face protection and make sure it is a good fit. Face protection alone is not sufficient to protect the eyes.

Wear "personal" sound protection, e.g. ear defenders.

Always wear a hard hat during thinning work, in high brush, and whenever there is a risk of injury due to falling objects.



Wear sturdy protective gloves made of a resistant material (e. g. leather).

STIHL can supply a comprehensive range of personal protective equipment.

Transporting the machine

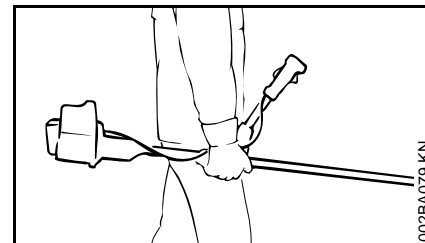
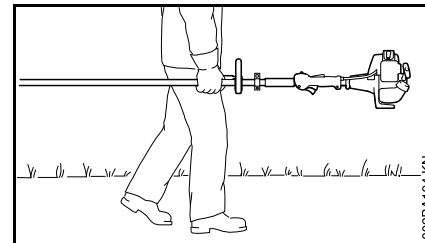

Always stop the engine.

Carry the machine hanging on the harness or by the shaft so that it is balanced.

To reduce the risk of cut injuries, fit transport guard on the cutting attachment, even when carrying the tool for short distances – see also "Transporting the Unit".



Avoid touching hot parts of the machine and gear-box – **risk of burns!**

By vehicle: When transporting in a vehicle, properly secure your machine to prevent turnover, damage and fuel spillage.

Before starting

Check that your power tool is properly assembled and in good condition – refer to appropriate chapters in the KombiEngine and KombiTool user manuals:

- Use only an approved combination of cutting attachment, deflector, handle and harness. All parts must be assembled properly and securely
- Check cutting attachment for correct and secure assembly and good condition
- Safety devices (e. g., deflector for cutting attachments, rider plate) for damage and/or wear. Always replace damaged parts. Do not use the machine with a damaged deflector or worn rider plate (if the writing and arrows are no longer discernible)
- Do not attempt to modify the controls or safety devices in any way – only work with the deflector fitted
- Keep the handles dry and clean – free from oil and dirt – this is important for safe control of the machine
- Adjust the harness and handle(s) to suit your height and reach Observe the chapter "Fitting the Harness"

To reduce the risk of personal injury, do not operate your power tool if it is damaged or not properly assembled!

To prepare for emergencies when using a harness: Practice setting down the machine quickly. To avoid damage, do not throw the unit to the ground when practicing.

Holding and guiding the machine

Always hold the unit firmly with both hands on the handles.

Make sure you always have a firm and secure footing.

For versions with bike handle

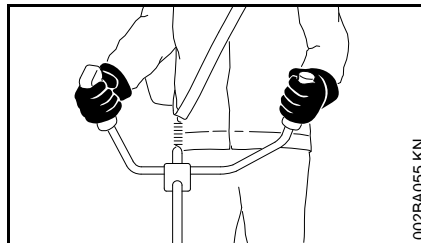

Right hand on control handle, left hand on grip on handlebar.

For versions with loop handle

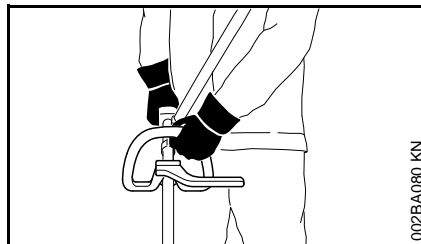

For versions with loop handle and loop handle with barrier bar, left hand on the loop handle, right hand on the control handle – even if you are left-handed.

Wrap your fingers and thumbs around the handles.

While working

Make sure you always have a firm and secure footing.

In the event of impending danger or in an emergency, switch off the engine immediately by moving the slide control/stop switch/stop button to **0** or **STOP**.

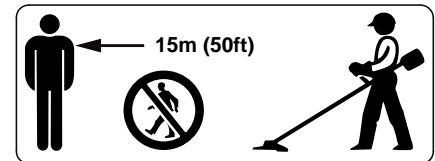

There is a risk of accident from ejected objects within a wide area around the working space, so you must ensure that there is no-one within a 15 m radius of the machine. This distance must also be maintained in relation to objects (vehicles, window panes) – **risk of property damage!** Even at distances beyond 15 m, the danger cannot be ruled out.



Avoid contact with the cutting attachment – **risk of injury!**

Check that the engine is properly idling so that the cutting tool will not continue rotating after you release the throttle trigger.

Check and correct the idle speed setting at regular intervals. If the attachment still rotates when the engine is idling, have

your dealer check your machine and make proper adjustments or repairs – see KombiEngine user manual. STIHL recommends you have this work done by a STIHL servicing dealer.

Take special care in slippery conditions – **damp, snow, ice**, on slopes or uneven ground.

Watch out for obstacles: tree stumps, roots – **risk of tripping or stumbling!**

Only work while standing on the ground, never on a ladder or mobile elevated work platform.

Never operate your power tool with one hand.

Be particularly alert and cautious when wearing hearing protection because your ability to hear warnings (shouts, alarms, etc.) is restricted.

Take breaks when you start getting tired or feeling fatigue – **risk of accidents!**

Work calmly and carefully – in daylight conditions and only when visibility is good. Proceed with caution, do not put others in danger.

If your power tool is subjected to unusually high loads for which it was not designed (e.g. heavy impact or a fall), always check that it is in good condition before continuing work – see also "Before Starting".

Make sure the safety devices are working properly. Never use a power tool that is no longer safe to operate. In case of doubt, contact a dealer.



Never work without protection suitable for the respective machine and cutting tool – **risk of injury** from ejected objects!



Check the work site – rocks, metal objects etc. could get caught up and ejected – potentially beyond a distance of 15 m – **risk of injury!** Such objects can also damage the cutting attachment and other property (e.g. parked vehicles, windows).



Be particularly careful when working on difficult, densely grown terrain.

When mowing in high shrubbery, under shrubbery and hedges: Hold the cutting tool at a working height of at least 15 cm – avoid risks to animals.

Examine the cutting attachment periodically at short intervals and as soon as you note any noticeable changes:

- Turn off the engine, hold the device securely, press the cutting attachment against the ground to stop it
- Check condition and secure fitting; watch out for cracks
- Ensure that the cutting blades are sharp
- Replace damaged or blunt cutting attachments immediately, even in the event of minor hairline cracks

Clean grass and plant residue off the cutting attachment mounting at regular intervals – remove any accumulated material from the cutting attachment and deflector.

To reduce the risk of injury, shut off the engine before replacing the cutting attachment.



The gear head becomes hot during operation. **Do not touch the gear housing – risk of burns!**

If a rotating cutting attachment makes contact with a rock or another hard object, sparks can be generated which may possibly ignite combustible materials. Also dried-out plants and brushwood are combustible, above all in hot and dry weather. If there is a risk of fire, do not use cutting attachments in the vicinity of combustible materials, dried-out plants or brushwood. It is mandatory that you ask the responsible forestry office about current fire hazards.

Using mowing heads

Enhance the cutting attachment deflector with the attached parts specified in the User Manual.

Only use the deflector with properly mounted blade that ensures the mowing line is restricted to the permissible length.

Always switch off the engine to adjust the mowing line for manually adjustable mowing heads – **risk of injury!**

Misuse with mowing lines that are too long reduces the working speed of the engine. The constant slipping of the clutch causes overheating and damage to important components (e. g. clutch, plastic housing parts) – e. g. due to the cutting attachment rotating during idling – **risk of injury!**

When using metal cutting attachments

STIHL recommends the use of original STIHL metal cutting attachments. These have been optimized for the machine and the user's requirements.

Metal cutting attachments rotate very fast, generating forces acting on the attachments and on the cuttings.

Metal cutting attachments must be sharpened in regular intervals in accordance with the instructions.

Unevenly sharpened metal cutting attachments generate an imbalance which may cause extreme loads on the machine – **risk of breakage!**

Dull or improperly sharpened cutting edges can put a higher load on the cutting attachment and increase the **risk of injury** from cracked or broken parts.

After each contact of the metal cutting attachment with hard objects (e.g. stones, rocks, metal parts), check it for damage (e.g. tears and deformation). Burrs and other visible accumulated material must be removed since they may come loose at any time while the machine is running and then be ejected – **risk of injury!**

Do not continue using or attempt to repair damaged or cracked cutting attachments by means of welding, straightening or modifying the shape (unbalanced).

Particles or pieces may come off and hit the operator or a bystander at a high speed – **risk of most severe injuries!**

To reduce the above-named risks involved in operating a metal cutting attachment, ensure that the diameter of your metal cutting attachment is not too big. Also, the attachment must not be too heavy. It must be made of high-quality materials and have a suitable geometry (shape, thickness).

To reduce the risk of injury, a metal cutting attachment not manufactured by STIHL must not be heavier, thicker, have a different shape or a diameter larger than the largest metal cutting attachment approved by STIHL for this power tool model.

After finishing work

After finishing work or before leaving the power tool unattended: Shut off the engine.

Clean the cutting attachment regularly after finishing work to remove dust, dirt, soil and plant debris – wear gloves – **risk of injury!**

Do not use any grease solvents when cleaning.

After cleaning it thoroughly, coat the surface of metal cutting attachments with a corrosion-proofing agent.

Maintenance and Repairs

Service the machine regularly. Do not attempt any maintenance or repair work not described in the KombiTool and KombiEngine instruction manuals. Have all other work performed by a servicing dealer.

STIHL recommends that you have servicing and repair work carried out exclusively by an authorized STIHL servicing dealer. STIHL dealers are regularly given the opportunity to attend training courses and are supplied with the necessary technical information.

Only use high-quality replacement parts in order to avoid the risk of accidents and damage to the machine. If you have any questions in this respect, consult a servicing dealer.

STIHL recommends the use of genuine STIHL replacement parts. They are specifically designed to match your model and meet your performance requirements.

To reduce the risk of injury, **always shut off the engine** before carrying out any maintenance or repairs or cleaning the machine.

Symbols on Deflectors

An **arrow** on the deflector shows the correct direction of rotation of the cutting attachments.

Some of the following symbols are applied to the outside of the deflector to indicate the approved combination of cutting attachment and deflector.



Deflector may be used with mowing heads.



Deflector must not be used with mowing heads.



Deflector may be used with grass cutting blades.



Deflector must not be used with grass cutting blades.



Deflector may be used with brush knives.



Deflector must not be used with brush knives.



Deflector must not be used with shredder blades.



Deflector must not be used with circular saw blades.

Harness / Strap

The harness is included in the scope of supply or available as a special accessory.

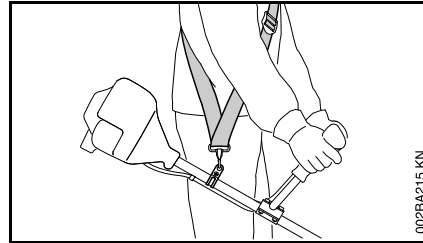

- Use a shoulder strap.
- With the engine running, attach the machine to the shoulder strap.

Grass cutting blades and brush knives must always be used in combination with a shoulder strap.

Circular saw blades must always be used in combination with a full harness with a quick-release system.

Mowing Head with Nylon Line

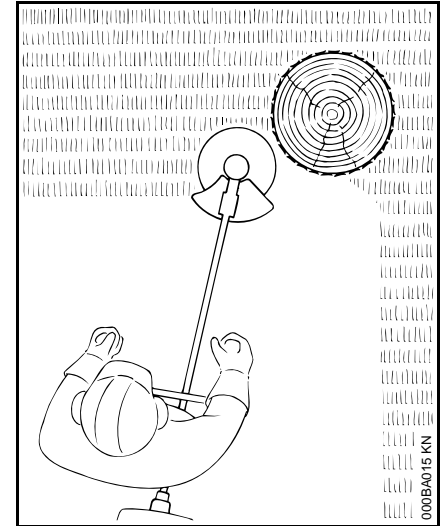

Nylon line achieves a soft cut for edging and trimming around trees, fence posts, etc. – less risk of damaging tree bark.

The mowing head comes with an instruction leaflet. Refill the mowing head with nylon line as described in the instruction leaflet.

! WARNING

To reduce the risk of serious injury, never use wire or metal-reinforced line in place of the nylon line.

STIHL Polycut Mowing Head with Polymer Blades

For mowing unobstructed edges of meadows (without posts, fences, trees or similar obstacles).

Check the wear limit marks!

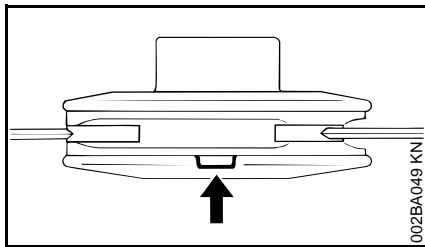

If one of the wear limit marks on the PolyCut mowing head is worn through (arrow): Do not continue using the mowing head. Install a new one. There is otherwise a **risk of injury** from thrown parts of the head.

It is important to follow the maintenance instructions for the PolyCut mowing head.

The PolyCut can also be equipped with mowing line in place of the polymer blades.

The mowing head comes with instruction leaflets. Equip the mowing head with polymers blades or nylon line as described in the instruction leaflets.

WARNING

Never use wire in place of the nylon mowing line – **risk of injury**.

Risk of Kickout (Blade Thrust) with Metal Cutting Attachments

WARNING



When using metal cutting attachments there is a risk of kickout when the rotating blade comes into contact with a solid object such as a tree trunk, branch, tree stump, rock or similar. The machine is thrown to the right or to the rear – opposite to the attachment's direction of rotation.

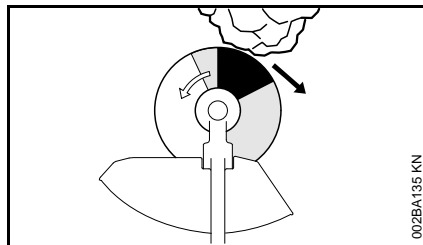

The **risk of kickout is greatest** when the **black area** of the rotating cutting attachment comes into contact with a solid object.

Grass Cutting Blade

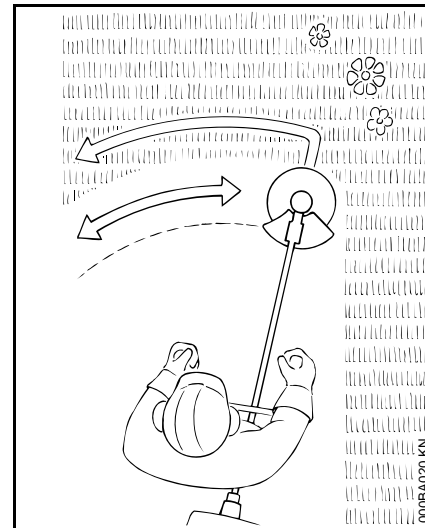

Use for grass and weeds only – sweep the brushcutter in an arc like a scythe.

WARNING

Improper use may damage the grass cutting blade – **risk of injury** from thrown parts.

Resharpener the grass cutting blade according to instructions when it has dulled noticeably.

Brush Knife

For cutting matted grass, wild growth and scrub and thinning young stands with a stem diameter of no more than 2 cm – do not cut thicker stems – **risk of accidents**.

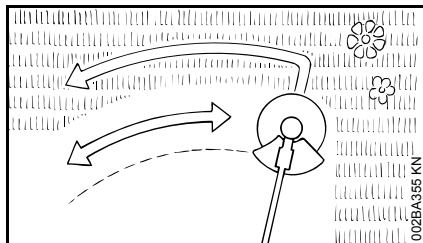

Use the brushcutter like a scythe (sweep it to the right and left) at ground level when cutting grass and thinning young stands.

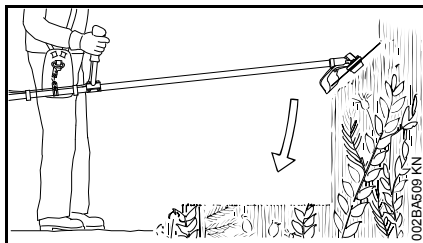

To cut wild growth and scrub, lower the brush knife down onto the growth to achieve a shredding effect – always keep the cutting attachment below hip level during this process.

Exercise extreme caution when using this method of cutting. The higher the cutting attachment is off the ground, the greater the risk of injury from cuttings being thrown sideways.

Warning! Improper use of a brush knife may cause it to crack, chip or shatter – **risk of injury** from thrown parts.

To reduce the risk of injury it is essential to take the following precautions:

- Avoid contact with stones, rocks, pieces of metal and other solid foreign objects.
- Never cut wood or shrubs with a stem diameter of more than 2 cm – use a circular saw blade for such work.
- Inspect the brush knife at regular short intervals for signs of damage. Do not continue working with a damaged brush knife.
- Resharpener the brush knife regularly and whenever it has dulled noticeably, and have it balanced if necessary (STIHL recommends a STIHL servicing dealer).

Circular Saw Blade

Suitable for cutting shrubs and trees with a maximum stem diameter of 4 cm.

Before starting the cut, accelerate the engine up to full throttle. Perform cut with uniform pressure.

Use circular saw blades only with a matching limit stop of the correct diameter.

! WARNING

To reduce the risk of blade damage, avoid contact with stones and the ground. Resharpener the blade properly in good time – dull teeth may result in the blade cracking and shattering and causing serious injury.

When felling, maintain a distance of at least two tree lengths from the next felling site.

Risk of kickout

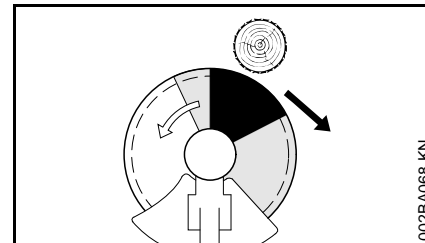

The risk of kickout is highest in the black area of the blade: Do not use this area of the circular saw blade for cutting.

There is also a risk of kickout when using the lighter shaded areas of the blade: These areas of the blade should only be used by experienced operators with specialized training.

STIHL recommends that you use the non-shaded area of the circular saw blade. Always start the cut with this area of the blade.

Approved KombiEngines

KombiEngines

Only use KombiEngines supplied or explicitly approved by STIHL for use with the attachment.

Depending on the cutting attachment used, always observe the chapter "Permissible combinations of cutting attachment, deflector, grip and harness".

This KombiTool may be operated only in combination with the following KombiEngines:

STIHL KM 55 R, KM 56 R, KM 85 R¹⁾,
KM 91 R, KM 94 R, KM 111 R, KM 131,
KM 131 R, KMA 130 R, KMA 135 R

WARNING

Loop-handled machines must be equipped with a barrier bar.

Brushcutters with split shaft

The KombiTool can also be fitted to STIHL brushcutters with a split shaft (T-models) (basic power tools).

This KombiTool can therefore also be used on the following machine:













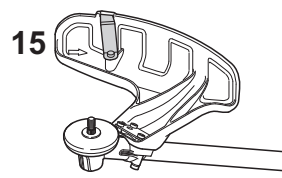





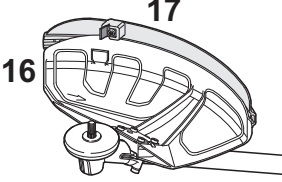
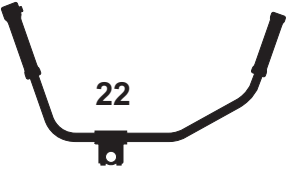





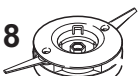

STIHL FR 131 T

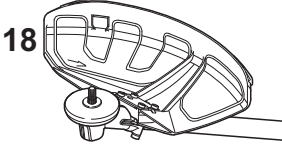
¹⁾ Only outside EU

WARNING

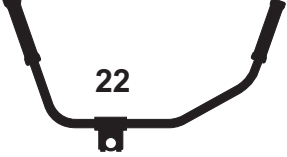
Refer to the user manual of the power tool for use of the barrier bar.

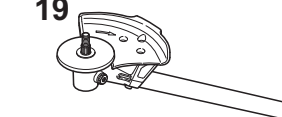
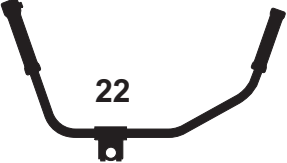
Approved Combinations of Cutting Attachment, Deflector, Handle and Harness

Cutting attachment		Deflector, limit stop	Handle	Carrying strap
1 	2 	15 	20  21	23  25 
3 	4 	16 	22 	24  25 
5 	6 			
7 	8 			
9 	10 			
11 	12 	18 	20  21	24  25 
13 			22 	
14 		19 	22 	26 

Permissible combinations

Choose the correct combination from the table depending on the cutting tool!

WARNING

For safety reasons only the cutting attachments, deflector, handle and harness versions within one line of the table may be combined with one another. No other combinations are permitted because of the **risk of accidents!**

WARNING

Loop-handled machines must be equipped with a barrier bar.

Cutting attachments

Mowing heads

- 1 STIHL SuperCut 20-2
- 2 STIHL AutoCut C 25-2
- 3 STIHL AutoCut 25-2
- 4 STIHL AutoCut C 26-2
- 5 STIHL AutoCut 36-2
- 6 STIHL PolyCut 20-3³⁾
- 7 STIHL DuroCut 20-2
- 8 STIHL PolyCut 28-2

Metal cutting tools

- 9 Grass cutting blade 230-2 (Ø 230 mm)
- 10 Grass cutting blade 260-2 (Ø 260 mm)
- 11 Grass cutting blade 230-4 (Ø 230 mm)

- 12 Grass cutting blade 230-8 (Ø 230 mm)
- 13 Brush knife 250-3¹⁾ (Ø 250 mm)
- 14 Circular saw blade 200-22 chisel tooth ¹⁾²⁾ (Ø 200 mm), circular saw blade 200-22 HP chisel tooth ¹⁾²⁾ (Ø 200 mm)

WARNING

Grass cutting blades, brush knives and circular saw blades of other, non-metal materials must not be used.

Deflectors, limit stop

- 15 Deflector for mowing heads
- 16 Deflector **with**
- 17 Skirt and blade for mowing heads
- 18 Deflector **without** skirt and blade for metal cutting attachments, items 9 to 14
- 19 Limit stop for circular saw blades

Handles

- 20 Loop handle **with**
- 21 Barrier bar
- 22 Bike handle

¹⁾ Not approved for KM 55 R, FS 56 R

²⁾ Not approved for FR 131 T, KM 55 R, KM 56 R, KM 85 R, KM 94 R, KM 111 R, KM 131 R, KMA 130 R, KMA 135 R

¹⁾ Not approved for KMA 135 R

Shoulder straps

- 23 Shoulder strap can be used
- 24 Shoulder strap must be used
- 25 Full harness can be used
- 26 Full harness must be used

Mounting the KombiTool

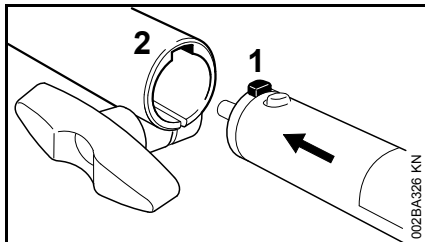

- Push the lug (1) on the drive tube into the slot (2) in the coupling sleeve as far as stop.

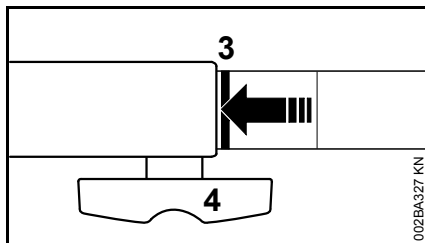

When correctly installed, the red line (3) (arrow point) must be flush with the end of the coupling sleeve.

- Tighten down the star knob (4) **firmly**.

Removing the KombiTool

- Reverse the above sequence to remove the drive tube.

Mounting the Deflector

Mounting the Deflector

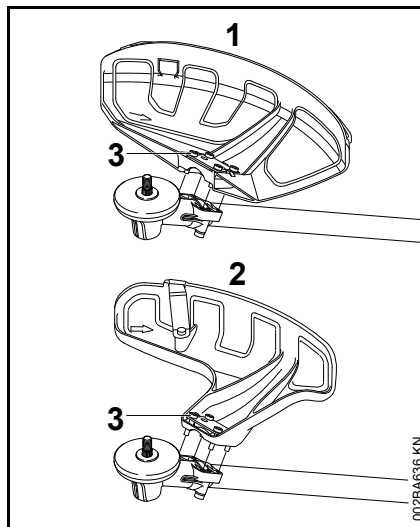

- 1 Deflector for mowing attachments
- 2 Deflector for mowing heads

Deflectors (1 and 2) are both mounted to the gearbox in the same way.

- Place the deflector on the gearbox flange.
- Insert the screws (3) and tighten them down firmly.

Fitting the Skirt and Blade

! WARNING

Risk of injury from thrown objects and contact with the cutting attachment. These parts must be fitted to the deflector (1) when you use a mowing head.

Fitting the Skirt

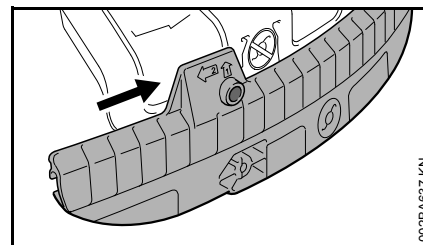

- Slide the lower guide slot of the skirt onto the deflector – it must snap into position.

Removing the Skirt

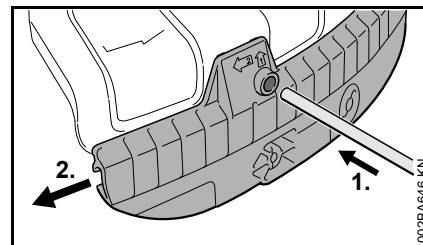

- Insert the stop pin into the hole in the skirt and use it to push the skirt to the left.
- Pull the skirt off the deflector.

Mounting the Blade

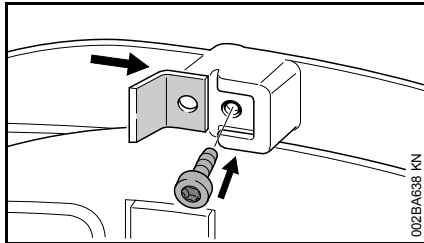

- Slide the line limiting blade into the guide on the skirt.
- Insert the screw and tighten it down firmly.

Mounting the Limit Stop

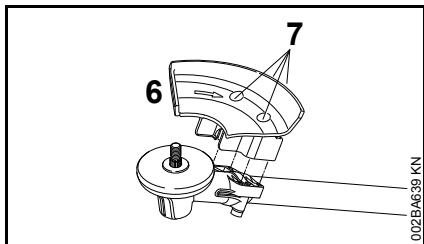

! WARNING

Risk of injury from thrown objects and contact with the cutting attachment. Always fit the limit stop (6) when you use a circular saw blade.

- Position the limit stop (6) on the gearbox flange.
- Insert the screws (7) and tighten them down firmly.

Mounting the Cutting Attachment

Placing power tool on the ground

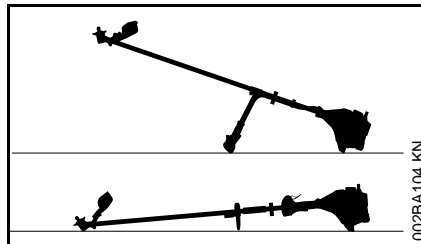

- Shut off the engine.
- Lay your power tool on its back so that the cutting attachment mounting face is pointing up.

Mounting Hardware for Cutting Attachments

The mounting hardware supplied depends on the cutting attachment that comes as original equipment with the new machine.

Machine supplied with mounting hardware

Mowing heads and metal cutting attachments may be mounted.

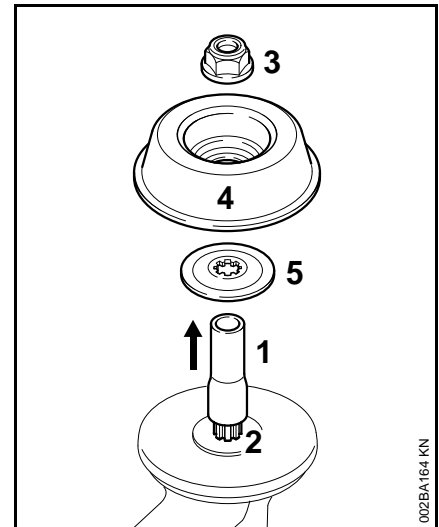

Depending on the cutting attachment, it may be necessary to use the nut (3), rider plate (4) and thrust washer (5).

These parts are included in a kit supplied with the machine and are also available as special accessories.

Removing the transport lock

- Pull the hose (1) off the shaft (2).

Machine supplied without mounting hardware

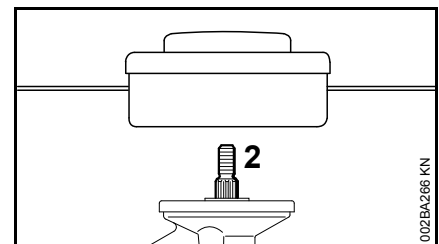

Only mowing heads may be used which mount directly to the shaft (2).

Blocking the Shaft

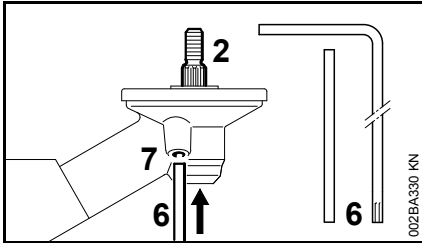

The output shaft (2) must be blocked with the stop pin (6) or screwdriver (6) to mount or remove cutting attachments. These parts come standard with the machine or are available as special accessories.

- Insert the stop pin (6) or screwdriver (6) in the hole (7) in the gearbox as far as stop – and apply slight pressure.
- Rotate shaft, nut or cutting attachment until the stop pin slips into position and blocks the shaft.

Removing the Mounting Hardware

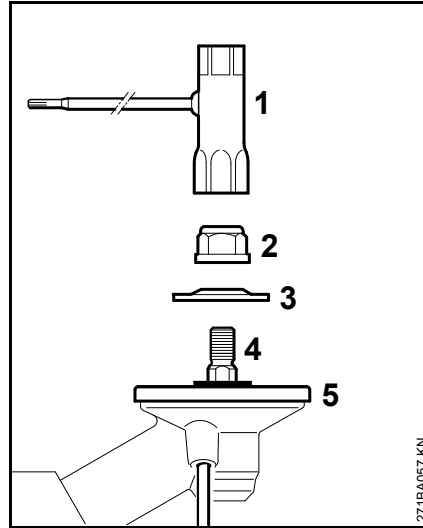

- Block the shaft.
- Use the combination wrench (1) to loosen and remove the nut (2) clockwise (left-hand thread).
- Take the thrust washer (3) off the shaft (4). Do not remove the thrust plate (5).

Mounting the Cutting Attachment



WARNING

Use a deflector that matches the cutting attachment – see "Mounting the Deflector".

Fitting the mowing head with screw mounting

Keep the supplement sheet for the mowing head in a safe place.

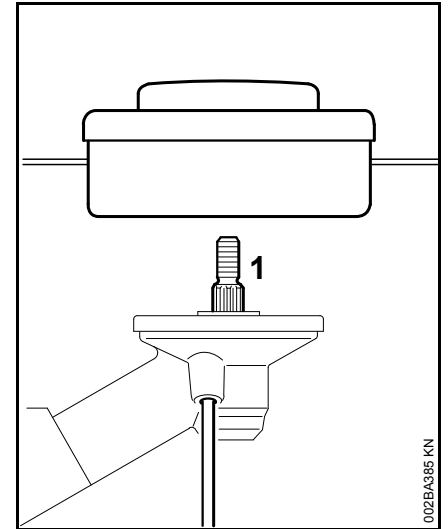

- Fit the thrust plate
- Turn the mowing head anticlockwise on the shaft (1) as far as it will go
- Retain the shaft
- Tighten the mowing head



NOTICE

Remove the tool that was used to block the shaft.

Removing the Mowing Head

- Retain the shaft
- Turn the mowing head clockwise

Mounting Metal Cutting Attachments

Keep the leaflet and packaging of the metal cutting attachment in a safe place.

! WARNING

Wear protective gloves to reduce the risk of direct contact with the sharp cutting edges.

Mount only one metal cutting attachment.

Check direction of rotation of cutting attachment

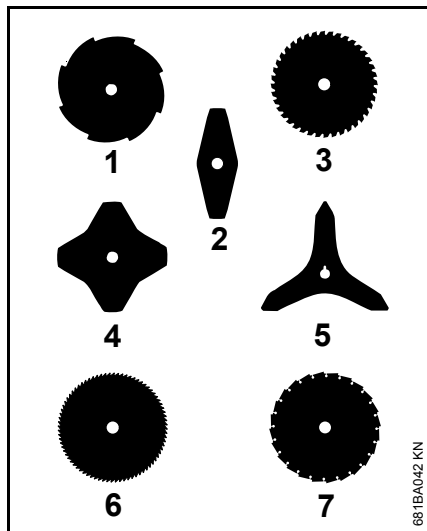

Cutting attachments 2, 4 and 5 may be mounted either way round – they must be turned over regularly to help avoid one-sided wear.

The cutting edges of cutting attachments 1, 3, 6 and 7 must point clockwise.

! WARNING

Direction of rotation is indicated by an arrow on the inside of the deflector.

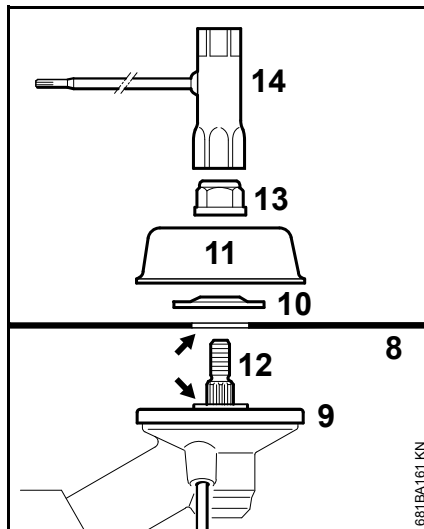

- Place the cutting attachment (8) on the thrust plate (9).

! WARNING

Collar (see arrow) must engage the cutting attachment's mounting hole.

Securing the cutting attachment

- Fit the thrust washer (10) – convex side must face up.
- Fit the rider plate (11).
- Block the shaft (12).
- Use the combination wrench (14) to screw the mounting nut (13) on to the output shaft counterclockwise and tighten it down firmly.

! WARNING

If the mounting nut has become too loose, fit a new one.

⚙ NOTICE

Remove the tool used to block the shaft.

Removing the Metal Cutting Attachment

! WARNING

Wear protective gloves to reduce the risk of direct contact with the sharp cutting edges.

- Block the shaft.
- Unscrew the mounting nut clockwise.
- Remove cutting attachment and its mounting hardware from the gearbox – but **do not** remove the thrust plate (9).

Fitting the Harness

The type and style of the harness, carrying ring and carabiner (spring hook) depend on the market.

The use of the harness is described in the chapter on "Approved Combinations of Cutting Attachment, Deflector, Handle and Harness".

Shoulder strap

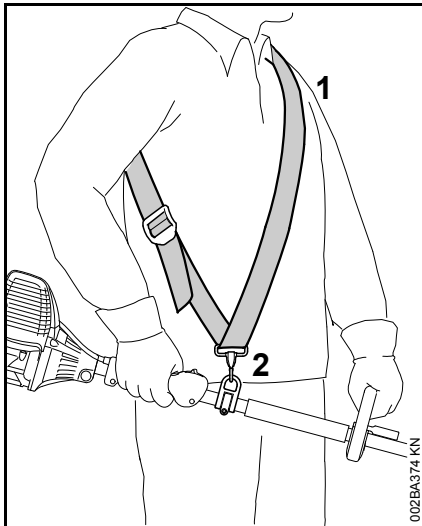

- Put on the shoulder strap (1).
- Adjust the length of the strap so that the carabiner (2) is about a hand's width below your right hip.
- Balance the machine – see "Balancing the Machine".

Full Harness

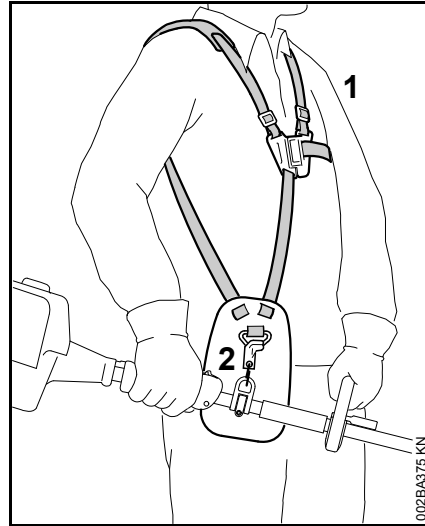

- Put on the full harness (1).
- Adjust the length of the strap so that the carabiner (2) is about a hand's width below your right hip.
- Balance the machine – see "Balancing the Machine".

Attaching Machine to Harness

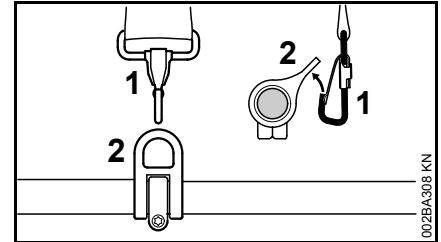

- Attach the carabiner (1) to the carrying ring (2) on the drive tube – hold the carrying ring steady.

Disconnecting Machine from Harness

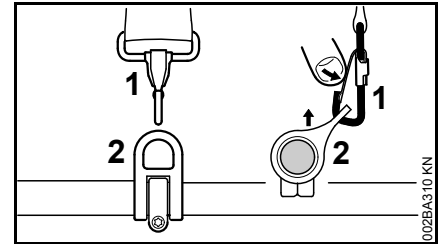

- Press down the bar on the carabiner (1) and pull the carrying ring (2) out of the carabiner.

Throwing Off the Machine

WARNING

The machine must be quickly thrown off in the event of imminent danger. Practice removing and putting down the machine as you would in an emergency. To avoid damage, do not throw the machine to the ground when practicing.

Practice quickly detaching the power tool from the carabiner as described under "Disconnecting Machine from Harness".

If you are using a shoulder strap:
Practice slipping the strap off your shoulder.

If you are using a full harness: Practice quickly opening the locking plate and slipping the harness straps off your shoulders.

Balancing the Machine

Balancing the Machine

The unit is balanced differently depending on the cutting attachment used.

Proceed as follows until the conditions specified under "Floating positions" have been met:

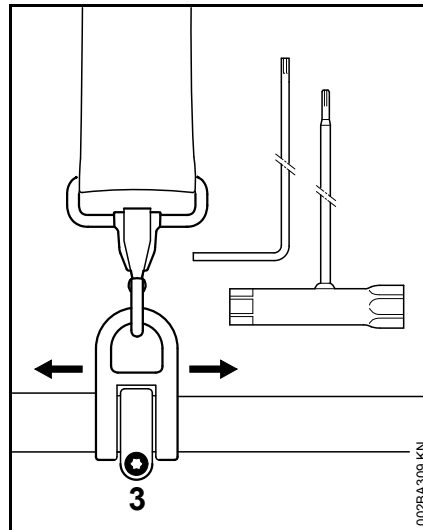

- Loosen the screw (3).
- Adjust the carrying ring.
- Tighten the screw moderately.
- Allow the unit to hang freely.
- Check the position obtained.

Floating positions

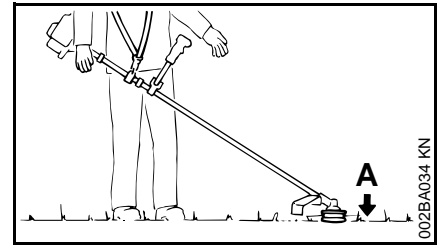

Mowing tools (A) such as mowing heads, grass cutting blades and brush knives

- should just touch the ground.

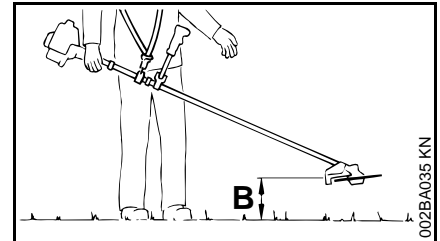

Circular saw blades (B)

- should "hover" about 20 cm (8 in) above the ground.

When the correct floating position has been reached:

- Tighten down the screw on the carrying ring firmly.

Starting / Stopping the Engine

Starting the Engine

Always follow the operating instructions for the KombiEngine and basic power tool.

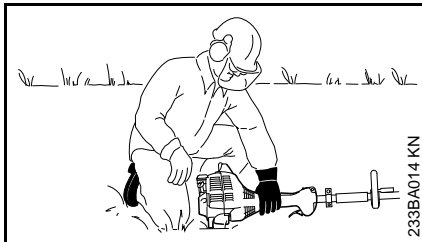
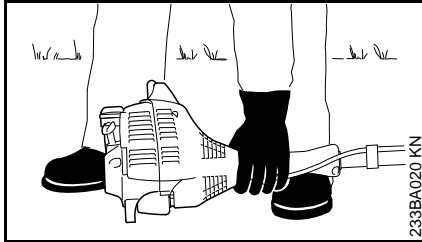

- Put the unit on the ground: It must rest securely on the engine support and the deflector.
- If fitted: Remove the transport guard from the cutting attachment.

To reduce the risk of accidents, check that the cutting attachment is not touching the ground or any other obstacles.

- Make sure you have a firm footing, either standing, stooping or kneeling.
- Hold the unit **firmly** on the ground with your left hand and press down – do not touch the throttle trigger or lockout lever – your thumb should be under the fan housing.



NOTICE

Do not stand or kneel on the drive tube.



WARNING

The cutting attachment may begin to move as soon as the engine starts. For this reason, blip the throttle after starting – the engine returns to idling speed.

The starting procedure is now as described in the instruction manual of the KombiEngine or basic power tool you are using.

Stopping the Engine

- See instruction manual of the KombiEngine or basic power tool.

Transporting the Unit

Using Transport Guard

The type of transport guard depends on the metal cutting attachment supplied with the machine. Transport guards are available as special accessories.

230 mm Grass Cutting Blades

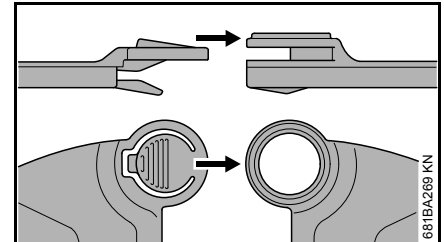
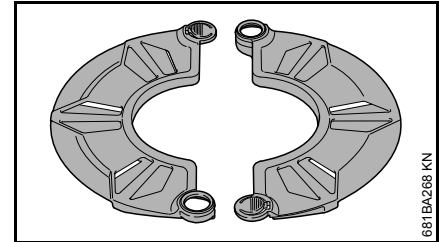

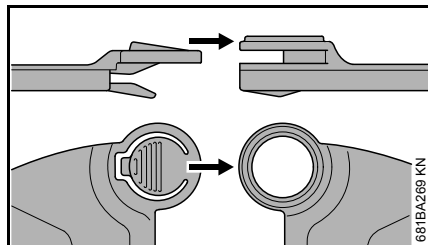
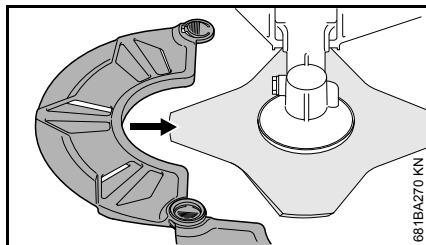

Grass Cutting Blades up to 260 mm

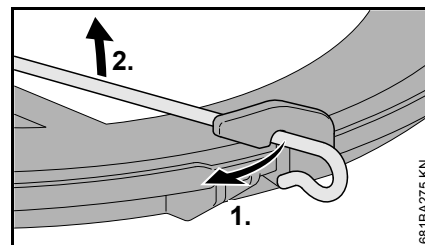
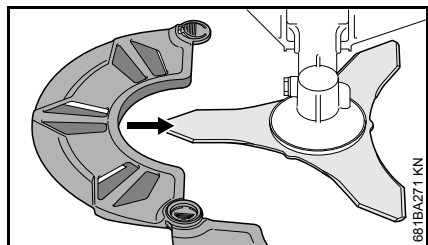
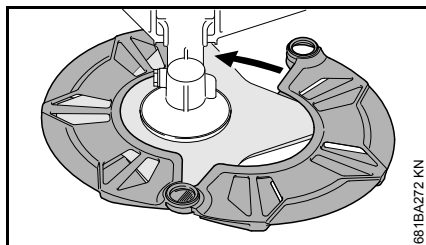
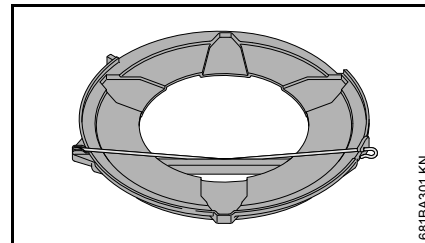

- Disconnect wire rod from the transport guard.
- Swing wire rod outwards.

250 mm Brush Knives

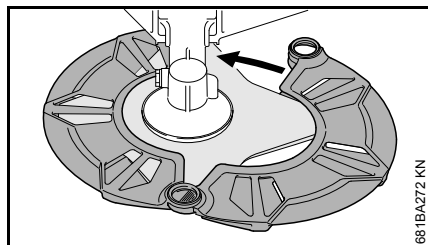
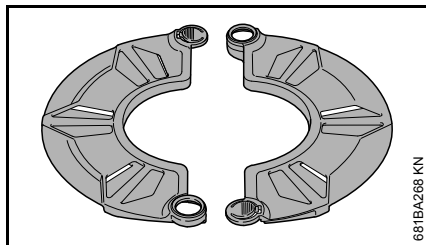

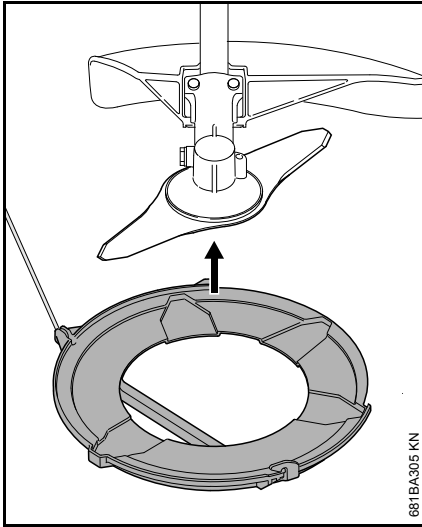

- Fit the transport guard on the cutting attachment from below.

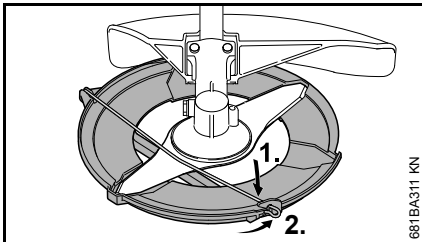

- Swing wire rod into position.
- Hook wire rod to the transport guard.

Circular Saw Blades

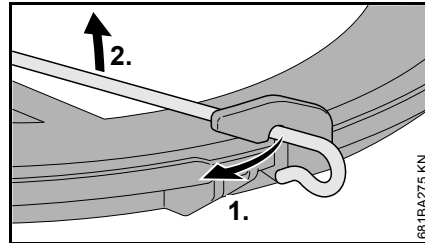
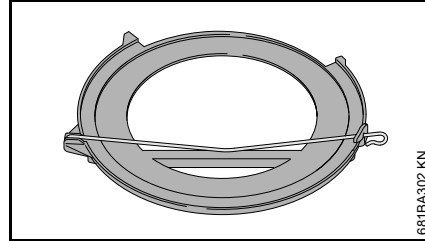

- Disconnect wire rod from the transport guard.

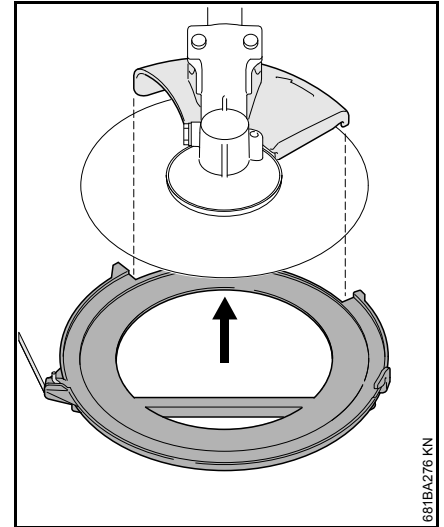

- Swing wire rod outwards.
- Fit transport guard on saw blade from below, making sure the limit stop is properly seated in the recess.

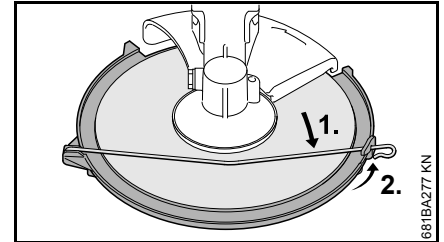

- Swing wire rod into position.
- Hook wire rod to the transport guard.

Lubricating the Gearbox

Gearbox without Screw Plug

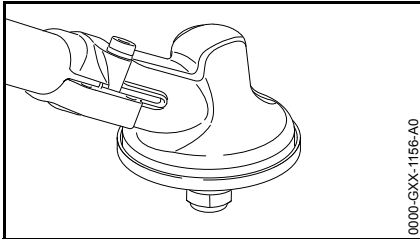

- If the gearbox has no screw plug: gearbox is maintenance-free and requires no re-lubrication.

Gearbox with Screw Plug

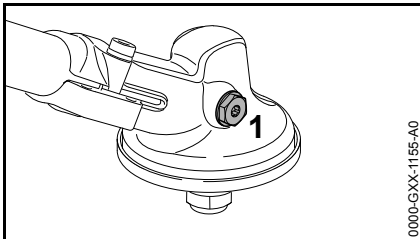

- If the gearbox has a screw plug (1): Check grease level after every 25 hours of operation and re-lubricate if necessary.

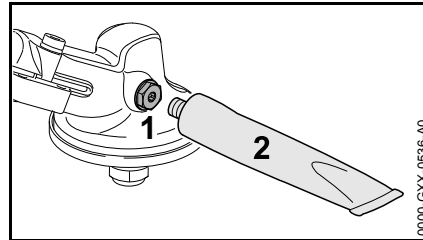

- Remove the screw plug (1).
- If no grease can be seen on the inside of the screw plug (1): Screw the tube (2) of STIHL gear lubricant (special accessory) into the filler hole.
- Squeeze no more than 5 g (1/5 oz) grease into the gearbox.

NOTICE

Do not completely fill the gearbox with grease.

- Unscrew the tube (2).
- Insert the screw plug (1) and tighten it down firmly.

Storing the Machine

For periods of about 3 months or longer

- Remove, clean and inspect the cutting attachment. Coat metal cutting attachments with corrosion inhibitor.
- Thoroughly clean the machine.
- If the KombiTool is removed from the KombiEngine and stored separately: Fit the protective cap on the drive tube to avoid dirt getting into the coupling.
- Store the machine in a dry and secure location – out of the reach of children and other unauthorized persons.

Sharpening Metal Cutting Blades

- Use a sharpening file (see "Special Accessories") to sharpen dull cutting attachments. In case of more serious wear or nicks: Resharpener with a grinder or have the work done by a dealer – STIHL recommends a STIHL servicing dealer.
- Sharpen frequently, take away as little metal as possible – two or three strokes of the file are usually enough.

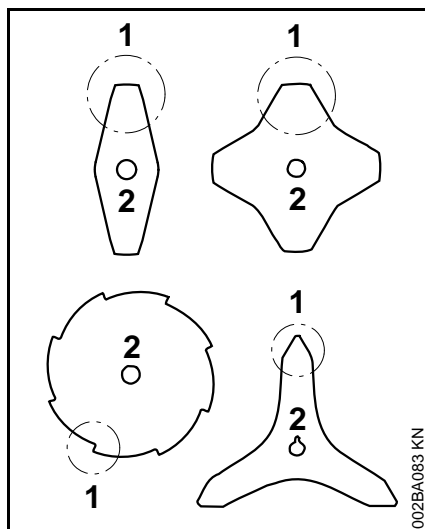

- Resharpener the teeth (1) uniformly – do not alter the contour of the parent blade (2) in any way.

See cutting attachment packaging for additional sharpening instructions. Keep the packaging for future reference.

Balancing

- After resharpener about 5 times, check the cutting attachment for out-of-balance on a STIHL balancer – see "Special Accessories" – or have it checked by a dealer and re-balanced as necessary – STIHL recommends a STIHL servicing dealer.

Maintaining the Mowing Head

Placing power tool on the ground

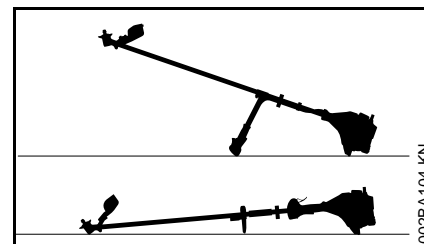

- Shut off the engine.
- Lay your power tool on its back so that the cutting attachment mounting face is pointing up.

Replacing Nylon Line

Always check the mowing head for signs of wear before replacing the nylon line.

! WARNING

If there are signs of serious wear, replace the complete mowing head.

The nylon mowing line is referred to as "nylon line" or "line" in the following.

The mowing head is supplied with illustrated instructions for replacing the nylon line. Keep the instructions for the mowing head in a safe place.

- If necessary, remove the mowing head.

Adjusting Nylon Line

STIHL SuperCut

Fresh line is advanced automatically if the remaining line is **at least 6 cm (2 1/2 in)** long. The blade on the deflector trims overlong lines to the correct length.

STIHL AutoCut

- With the engine running, hold the rotating mowing head above the grass surface.
- Tap it on the ground once – fresh line is advanced and the blade on the deflector trims it to the right length.

Fresh line is advanced every time the mowing head is tapped on the ground. For this reason observe the mowing head's cutting performance during operation. If the mowing head is tapped on the ground too often, the line limiting blade will unnecessarily cut off unused lengths of nylon line.

Line feed operates only if both lines are still at least **2.5 cm (1 in)** long.

STIHL TrimCut



WARNING

To reduce the risk of injury, always shut off the engine before adjusting the nylon line by hand.

- Pull the spool up – rotate it about 1/6 turn counterclockwise until it engages – and allow it to spring back.
- Pull ends of the lines outward.

Repeat the above procedure as necessary until both lines reach the limiter blade on the deflector.

Rotating the spool from one stop to the next advances about **4 cm (1 1/2 in)** of fresh line.

Replacing Nylon Line

STIHL PolyCut

Precut lengths of nylon line can be fitted to the PolyCut in place of the cutting blades.

STIHL DuroCut, STIHL PolyCut



WARNING

To reduce the risk of injury, always shut off the engine before refilling the mowing head.

- Fit precut lengths of nylon line in the mowing head as described in the instructions supplied.

Replacing Cutting Blades

STIHL PolyCut

Always check the mowing head for signs of wear before installing new cutting blades.



WARNING

If there are signs of serious wear, replace the complete mowing head.

The thermoplastic cutting blades are referred to as "blades" in the following.

The mowing head is supplied with illustrated instructions for replacing the blades. Keep the instructions for the mowing head in a safe place.



WARNING

To reduce the risk of injury, always shut off the engine before installing the blades.

- Remove the mowing head.
- Replace blades as shown in the illustrated instructions.
- Mount the mowing head on the machine.

Maintenance and Care

The following intervals apply to normal operating conditions only. If your daily working time is longer or operating conditions are difficult, shorten the specified intervals accordingly.

All accessible screws and nuts

- Retighten if necessary

Cutting attachments

- Inspect for damage, check tightness before starting work and after every refueling stop
- Replace if damaged
- Sharpen metal cutting attachments before starting work if necessary

Gearbox lubrication (only gearbox versions with screw plug)

- Check weekly
- Replenish as necessary

Safety labels

- Replace illegible safety labels

Minimize Wear and Avoid Damage

Observing the instructions in this manual and the KombiEngine manual helps reduce the risk of unnecessary wear and damage to the power tool.

The power tool must be operated, maintained and stored with the due care and attention described in these instruction manuals.

The user is responsible for all damage caused by non-observance of the safety precautions, operating and maintenance instructions. This includes in particular:

- Alterations or modifications to the product not approved by STIHL.
- Using tools or accessories which are neither approved or suitable for the product or are of a poor quality.
- Using the product for purposes for which it was not designed.
- Using the product for sports or competitive events.
- Consequential damage caused by continuing to use the product with defective components.

Maintenance Work

All the operations described in the chapter on "Maintenance and Care" must be performed on a regular basis. If these maintenance operations cannot be performed by the owner, they should be performed by a servicing dealer.

STIHL recommends that you have servicing and repair work carried out exclusively by an authorized STIHL

servicing dealer. STIHL dealers are regularly given the opportunity to attend training courses and are supplied with the necessary technical information.

If these maintenance operations are not carried out as specified, the user assumes responsibility for any damage that may occur. Among other parts, this includes:

- Corrosion and other consequential damage resulting from improper storage.
- Damage to the product resulting from the use of poor quality replacement parts.

Parts Subject to Wear and Tear

Some parts of the power tool are subject to normal wear and tear even during regular operation in accordance with instructions and, depending on the type and duration of use, have to be replaced in good time. Among other parts, this includes:

- Cutting attachments (all types)
- Mounting hardware for cutting attachments
- Deflectors for cutting attachments

Main Parts

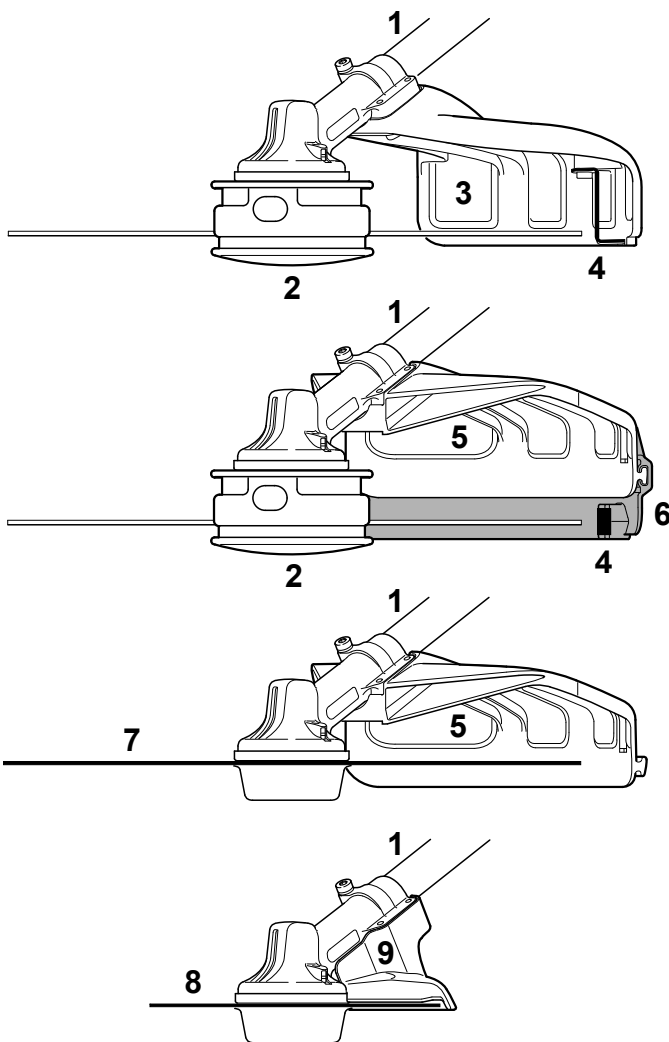

- 1 Drive tube
- 2 Mowing head
- 3 Deflector for mowing heads only
- 4 Line limiting blade
- 5 Deflector for all mowing attachments
- 6 Skirt for mowing heads
- 7 Metal mowing attachment
- 8 Circular saw blade
- 9 Limit stop for circular saw blades only

002BA644-KN

Specifications

Engine speed

Max. output shaft speed on cutting attachment with KombiEngine:

KM 55 R:	7500 rpm
KM 56 R:	7600 rpm
KM 85 R:	7900 rpm
KM 91 R:	7150 rpm
KM 94 R:	7300 rpm
KM 111 R:	7150 rpm
KM 131 / 131 R:	7150 rpm
KMA 130 R:	6070 rpm
KMA 135 R	6070 rpm

Max. output shaft speed (cutting attachment) on STIHL brushcutters with split shaft (T models):

FR 131 T:	7150 rpm
-----------	----------

Weight

without cutting attachment and deflector:	1.2 kg
---	--------

Sound and Vibration Levels

Noise and vibration data measurements on power tools with the FS-KM KombiTool include idling and rated maximum speed with the same duration of exposure.

For further details on compliance with Vibration Directive 2002/44/EC see www.stihl.com/vib

Sound pressure level L_{peq} to ISO 7917

with mowing head	
KM 85 R with loop handle:	95 dB(A)
with metal mowing tool	
KM 85 R with loop handle:	94 dB(A)

Sound pressure level L_{peq} to ISO 22868

with mowing head	
KM 55 R with loop handle:	94 dB(A)
KM 56 R with loop handle:	94 dB(A)
KM 94 R with loop handle:	93 dB(A)
KM 111 R with loop handle:	96 dB(A)
KM 131 with bike handle:	98 dB(A)
KM 131 R with loop handle:	98 dB(A)
FR 131 T:	97 dB(A)
with metal mowing tool	
KM 55 R with loop handle:	93 dB(A)
KM 56 R with loop handle:	94 dB(A)
KM 94 R with loop handle:	92 dB(A)
KM 111 R with loop handle:	96 dB(A)
KM 131 with bike handle:	97 dB(A)
KM 131 R with loop handle:	97 dB(A)
FR 131 T:	97 dB(A)

Sound pressure level L_{peq} in accordance with EN 50636-2-91

with mowing head	
KM 130 R with loop handle:	83 dB(A)
KM 135 R with loop handle:	84 dB(A)

with metal mowing tool	
KM 130 R with loop handle:	79 dB(A)
KM 135 R with loop handle:	79 dB(A)

Sound power level L_w to ISO 10884

with mowing head	
KM 85 R with loop handle:	110 dB(A)
with metal mowing tool	
KM 85 R with loop handle:	109 dB(A)

Sound power level L_w to ISO 22868

with mowing head	
KM 55 R with loop handle:	107 dB(A)
KM 56 R with loop handle:	106 dB(A)
KM 94 R with loop handle:	107 dB(A)
KM 111 R with loop handle:	108 dB(A)
KM 131 with bike handle:	109 dB(A)
KM 131 R with loop handle:	109 dB(A)
FR 131 T:	110 dB(A)
with metal mowing tool	
KM 55 R with loop handle:	106 dB(A)
KM 56 R with loop handle:	106 dB(A)
KM 94 R with loop handle:	107 dB(A)
KM 111 R with loop handle:	108 dB(A)
KM 131 with bike handle:	109 dB(A)
KM 131 R with loop handle:	109 dB(A)
FR 131 T:	109 dB(A)

Sound power level L_w in accordance with EN 50636-2-91

with mowing head		
KM 130 R with loop handle:	93 dB(A)	
KM 135 R with loop handle:	94 dB(A)	
with metal mowing tool		
KMA 130 R with loop handle:	88 dB(A)	
KM 135 R with loop handle:	91 dB(A)	

Vibration level $a_{hv,eq}$ to ISO 7916

with mowing head	Handle, left	Handle, right
KM 85 R with loop handle:	4.6 m/s ²	6.0 m/s ²
with metal mowing tool	Handle, left	Handle, right
KM 85 R with loop handle:	5.2 m/s ²	6.2 m/s ²

Vibration level $a_{hv,eq}$ in accordance with ISO 22867

with mowing head	Handle, left	Handle, right
KM 55 R with loop handle:	7.5 m/s ²	8.0 m/s ²
KM 56 R with loop handle:	6.3 m/s ²	6.0 m/s ²
KM 94 R with loop handle:	5.4 m/s ²	6.3 m/s ²
KM 111 R with loop handle:	4.5 m/s ²	4.6 m/s ²

with mowing head	Handle, left	Handle, right
KM 131 with bike handle:	4.9 m/s ²	3.9 m/s ²
KM 131 R with loop handle:	5.4 m/s ²	4.9 m/s ²
FR 131 T:	4.7 m/s ²	4.3 m/s ²
with metal mowing tool	Handle, left	Handle, right
KM 55 R with loop handle:	6.3 m/s ²	8.0 m/s ²
KM 56 R with loop handle:	5.5 m/s ²	6.0 m/s ²
KM 94 R with loop handle:	4.7 m/s ²	5.4 m/s ²
KM 111 R with loop handle:	4.2 m/s ²	3.7 m/s ²
KM 131 with bike handle:	5.0 m/s ²	4.2 m/s ²
KM 131 R with loop handle:	4.0 m/s ²	4.3 m/s ²
FR 131 T:	3.9 m/s ²	2.9 m/s ²

Vibration level $a_{hv,eq}$ in accordance with EN 50636-2-91

with mowing head	Handle, left	Handle, right
KM 130 R with loop handle:	4.4 m/s ²	4.3 m/s ²
KM 135 R with loop handle:	4.9 m/s ²	3.0 m/s ²
with metal mowing tool	Handle, left	Handle, right
KM 130 R with loop handle:	4.4 m/s ²	3.7 m/s ²
KM 135 R with loop handle:	5.0 m/s ²	2.9 m/s ²

The K-factor in accordance with Directive 2006/42/EC is 2.0 dB(A) for the sound pressure level and sound power level; the K-factor in accordance with Directive 2006/42/EC is 2.0 m/s² for the vibration level.

REACH

REACH is an EC regulation and stands for the Registration, Evaluation, Authorisation and Restriction of Chemical substances.

For information on compliance with the REACH regulation (EC) No. 1907/2006 see www.stihl.com/reach.

Maintenance and Repairs

Users of this machine may only carry out the maintenance and service work described in this user manual. All other repairs must be carried out by a servicing dealer.

STIHL recommends that you have servicing and repair work carried out exclusively by an authorized STIHL servicing dealer. STIHL dealers are regularly given the opportunity to attend training courses and are supplied with the necessary technical information.

When repairing the machine, only use replacement parts which have been approved by STIHL for this power tool or are technically identical. Only use high-quality replacement parts in order to avoid the risk of accidents and damage to the machine.

STIHL recommends the use of original STIHL replacement parts.

Original STIHL parts can be identified by the STIHL part number, the **STIHL** logo and the STIHL parts symbol  (the symbol may appear alone on small parts).

Disposal

Observe all country-specific waste disposal rules and regulations.

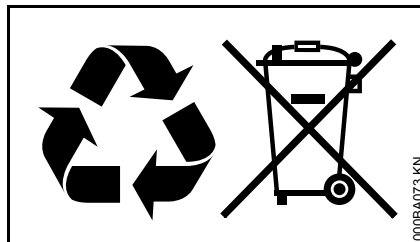

STIHL products must not be thrown in the garbage can. Take the product, accessories and packaging to an approved disposal site for environment-friendly recycling.

Contact your STIHL servicing dealer for the latest information on waste disposal.

EC Declaration of Conformity

ANDREAS STIHL AG & Co. KG
Badstr. 115
D-71336 Waiblingen

Germany

declare under our sole responsibility that

Designation: Scythe
KombiTool

Make: STIHL
Series: FS-KM

Serial identification
number: 4180

conforms to the relevant provisions of Directives 2006/42/EC and 2000/14/EC and has been developed and manufactured in compliance with the following standards in the versions valid on the date of production:

EN ISO 12100, EN ISO 11806-1 (in conjunction with the specified KM models).

EN ISO 12100, EN 60335-1, EN 50636-2-91 (in conjunction with the specified KMA models).

EN ISO 12100, EN ISO 11806-2 (in conjunction with the specified FR models).

The measured and the guaranteed sound power level have been determined in accordance with Directive 2000/14/EC, Annex V, and standard ISO 10884.

Measured sound power level

with KM 55 R: 107 dB(A)
with KM 56 R: 106 dB(A)
with KM 85 R: 111 dB(A)
with KM 94 R: 106 dB(A)
with KM 111 R: 108 dB(A)
with KM 131 / 131 R: 109 dB(A)
with KMA 130 R: 93 dB(A)
with KMA 135 R: 94 dB(A)
with FR 131 T: 110 dB(A)

Guaranteed sound power level

with KM 55 R: 109 dB(A)
with KM 56 R: 108 dB(A)
with KM 85 R: 112 dB(A)
with KM 94 R: 108 dB(A)
with KM 111 R: 110 dB(A)
with KM 131 / 131 R: 111 dB(A)
with KMA 130 R: 95 dB(A)
with KMA 135 R: 96 dB(A)
with FR 131 T: 112 dB(A)

Technical documents deposited at:

ANDREAS STIHL AG & Co. KG
Produktzulassung

The year of manufacture is specified on the power tool.

Waiblingen, 15.07.2021

ANDREAS STIHL AG & Co. KG

pp



Dr. Jürgen Hoffmann

Director Product Certification &
Regulatory Affairs



**UKCA Declaration of
Conformity**

ANDREAS STIHL AG & Co. KG

Badstr. 115

D-71336 Waiblingen

Germany

declare under our sole responsibility that

Designation: Scythe
KombiTool

Make: STIHL

Series: FS-KM

Serial identification
number: 4180

conforms to the relevant provisions of the UK regulations Supply of Machinery (Safety) Regulations 2008 and Noise Emission in the Environment by Equipment for use Outdoors Regulations 2001 and has been manufactured in compliance with the following standards in the versions valid on the date of production:

EN ISO 12100, EN ISO 11806-1 (in conjunction with the specified KM models).

EN ISO 12100, EN 60335-1, EN 50636-2-91 (in conjunction with the specified KMA models).

EN ISO 12100, EN ISO 11806-2 (in conjunction with the specified FR models).

The measured and guaranteed sound power levels were determined in accordance with the UK regulation Noise Emission in the Environment by Equipment for Use Outdoors Regulations 2001, Schedule 8, using the ISO 10884 standard.

Measured sound power level

with KM 55 R:	107 dB(A)
with KM 56 R:	106 dB(A)
with KM 85 R:	111 dB(A)
with KM 94 R:	106 dB(A)
with KM 111 R:	108 dB(A)
with KM 131 / 131 R:	109 dB(A)
with KMA 130 R:	93 dB(A)
with KMA 135 R:	94 dB(A)
with FR 131 T:	110 dB(A)

Guaranteed sound power level

with KM 55 R:	109 dB(A)
with KM 56 R:	108 dB(A)
with KM 85 R:	112 dB(A)
with KM 94 R:	108 dB(A)
with KM 111 R:	110 dB(A)
with KM 131 / 131 R:	111 dB(A)
with KMA 130 R:	95 dB(A)
with KMA 135 R:	96 dB(A)
with FR 131 T:	112 dB(A)

Technical documents deposited at:

ANDREAS STIHL AG & Co. KG

The year of manufacture is indicated on the power tool.

Waiblingen, 15.07.2021

ANDREAS STIHL AG & Co. KG

pp

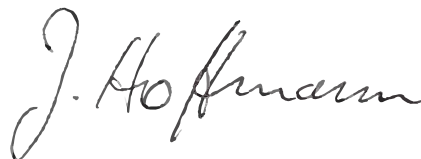

Dr. Jürgen Hoffmann

Director Product Certification &
Regulatory Affairs



0458-407-0121-C

englisch



www.stihl.com



0458-407-0121-C